

BEYAZLI GRUP LTD. ŞTİ

BESS



BEYAZLI GRUP



"We are heading into the future with confidence"



PLANT PRICE

178.285 USD

PRS 602 MACHINE DAILY CAPACITY (8 HOURS) 400 m² PAVING BLOCKS / 6.000 CONCRETE HOLLOW BLOCKS

FACTORY : TRABZON – ERZURUM DEVLET KARAYOLU ÜZERİ 9.Km. AKOLUK BELEDİYE KARŞISI – ÇAĞLAYAN / TRABZON / TURKEY

FACTORY : +90 462 357 30 62 / OFFICE : +90 462 321 07 78 / GSM : +90 549 325 66 70 / WEB : www.bessconcreteblockmachine.com / Email : abdoul@beyazligroup.com



Please consider the environment before printing this document

PLANT INSTALLATION LAYOUT

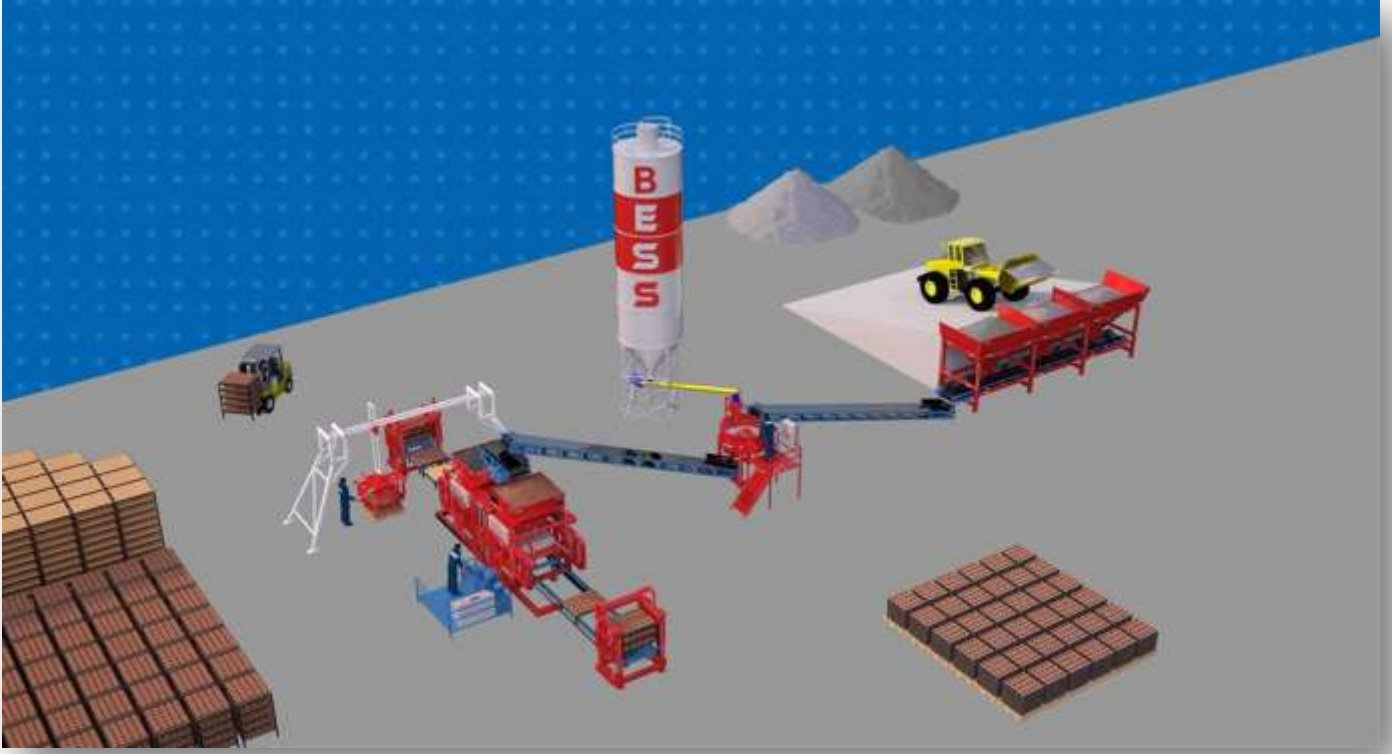

PLANT DESCRIPTION

PRS 602 – MACHINE : MACHINE IS DESIGNED WITH AUTOMATIC OPERATING SYSTEM AND MORTAR PLANT IS ON THE GROUND. DESIGNED TO WORK 24 HOURS. WE MANUFACTURE PLANTS WITH DIFFERENT AUTOMATION SYSTEMS AND CAPACITIES. FOR FURTHER INFORMATION PLEASE CONTACT YOUR NEAREST CUSTOMER REPRESENTATIVE.

EQUIPMENT LIST WITH PRICES, PREPARED RELATED TO THE NUMBERED INSTALLATION LAYOUT IS GIVEN BELOW. SAMPLE LAYOUT IS PREPARED AS TURNKEY PROJECT TO COMPLETE PLANT. CONTAINED EQUIPMENTS CAN BE REMOVED, REDUCED OR TO BE INCREASED. ([Please visit our website and ask for offer](#))

FOR A PLANT WITH THESE FEATURES THE RECOMMENDED CURING AND STOCK AREA SHOULD BE MINIMUM **2.000 m²**. THERE IS NO OBLIGATION FOR ROOFING. THE PREPARED CONCRETE FLOOR SHOULD BE MINIMUM **1/3** OF THE TOTAL PLANT AREA.

PRS 602 MACHINE SHIPPING VOLUME

EXCEPT THE PALLETS 1 PIECES 40’Ft OT / 3 PIECES 40’Ft HQ CONTAINER

FACTORY : TRABZON – ERZURUM DEVLET KARAYOLU ÜZERİ 9.Km. AKOLUK BELEDİYE KARŞISI – ÇAĞLAYAN / TRABZON / TURKEY

FACTORY : +90 462 357 30 62 / OFFICE : +90 462 321 07 78 / GSM : +90 549 325 66 70 / WEB : www.bessconcreteblockmachine.com / Email : abdoul@beyazligroup.com



PRICE LIST ACCORDING TO THE INSTALLATION LAYOUT

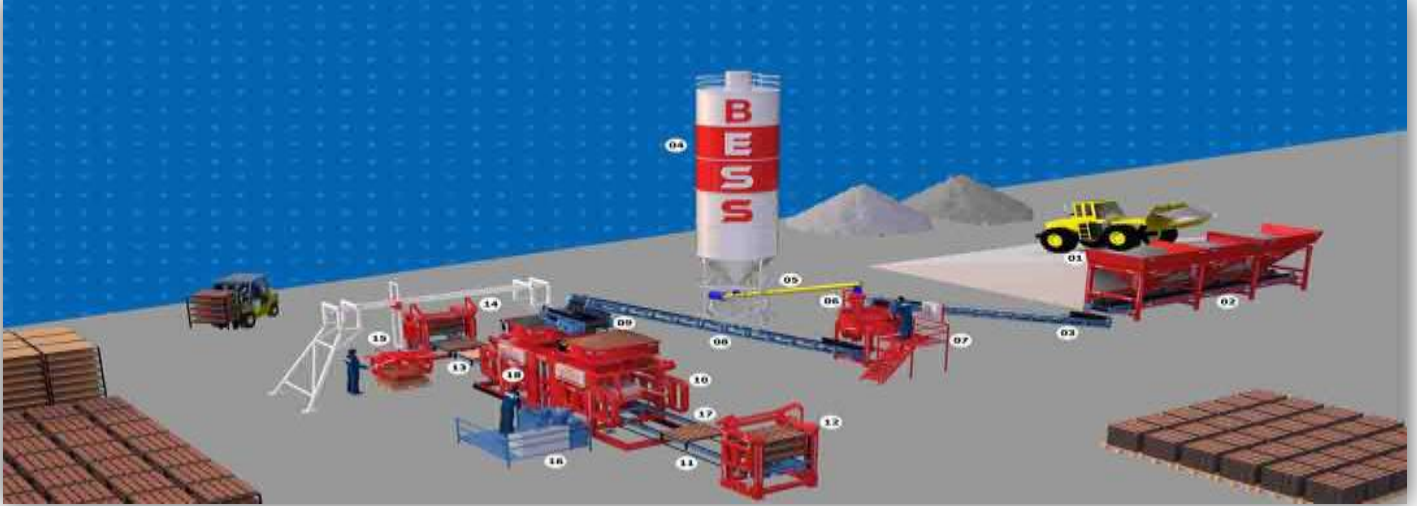

No	DESCRIPTION	QUANTITY	PRICE(USD)	TOTAL(USD)
01	24 m ³ -3 COMPARTMENT AGREGA HOPPER (BOTTOM VIBRATION)	1	9.450	9.450
02	WEIGHING BELT UNDER THE 3 COMPARTMENT HOPPER 9 mt	1	2.900	2.900
03	BELT CONVEYOR (8.5 mt x 0,50 mt x 8 mm) (FIXED)	1	2.575	2.575
04	50 TON CEMENT SILO (BASIC MODEL-FEEDING/DISCHARGE PIPE)	1	9.800	9.800
05	CEMENT FEEDING SCREW 200 DIAMETER 7-9 METER RANGE	1	3.755	3.755
06	50 KG CEMENT SCALE HOPPER (1 BAG)	1	750	750
√	MIXER OPERATOR PLATFORM	1	625	625
07	0,35 m ³ PAN MIXER(BOTTOM TRANSMISSION-ABRASION SHEET METAL)	1	12.250	12.250
08	MINI BELT CONVEYOR BETWEEN MACHINE HOPPERS (LEFT-RIGHT MOVABLE)	1	2.950	2.950
09	BELT CONVEYOR (10 mt x 0,50 mt x 8 mm) (FIXED)	1	850	850
10	PRS 602 CONCRETE BLOCK(PAVER-CURBSTONE) MACHINE AUTOMATIC (DOUBLE HOPPER)	1	53.200	53.200
√	6/16 AUTOMATIC MACHINE HYDRAULIC UNIT	1	3.695	3.695
11	FRONT OUTPUT CHAIN CONVEYOR	1	2.750	2.750
12	FRONT FULL PALLET STACKING ROBOT	1	6.750	6.750
13	REAR ENTRY CLAWED CONVEYOR	1	2.750	2.750
14	REAR EMPTY PALLET ROBOT (UNLOADER)	1	6.750	6.750
15	MANUAL COLLECTING ROBOT	1	14.500	14.500
√	MACHINE OPERATOR PLATFORM	1	625	625
16	6/16 AUTOMATIC MACHINE ELECTRIC UNIT (PLC)	1	3.850	3.850
√	6/16 AUTOMATIC MORTAR SYSTEM ELECTRIC UNIT	1	2.250	2.250
17	6 SERIAL / FRAMED PROFILED WOODEN PALLET	1000	30	30.000
18	DIFFERENT MODELS PAVING BLOCK MOULDS (ST 52)	1	3.500	3.500
√	COMPRESSOR 100 lt (FOR AUTOMATIC MORTAR UNIT INSTALLATION)	1	1.140	1.140
√	COMPRESSOR 100 lt -PNEUMATIC AIR INSTALLATION	1	620	620
ONLY :			SUB TOTAL(USD) :	178.285

FACTORY : TRABZON – ERZURUM DEVLET KARAYOLU ÜZERİ 9.Km. AKOLUK BELEDİYE KARŞISI – ÇAĞLAYAN / TRABZON / TURKEY

FACTORY : +90 462 357 30 62 / OFFICE : +90 462 321 07 78 / GSM : +90 549 325 66 70 / WEB : www.bessconcreteblockmachine.com / Email : abdoul@beyazligroup.com



Please consider the environment before printing this document



PRODUCT DESCRIPTION ACCORDING TO THE PLANT INSTALLATION LAYOUT

(01) – 24 m³ 3 COMPARTMENT AGREGA HOPPER (BOTTOM VIBRATION)



THIS HOPPER IS THE EQUIPMENT FOR MATERIALS AS SAND, GRAVEL, STONE DUST ETC. NEEDED FOR THE MIXTURE. UNDER EACH HOPPER ARE 1 UNLOADING COVERS. **CHASSIS** IS MANUFACTURED TO THE NORMS OF ISO 9001 QUALITY AND ACCORDING TO ALL DIN NORMS USING 150 x 100 x 6 mm. THICK PROFILE AND METAL SHEET. THICK METAL SHEET IS USED. METAL SHEET, THE FLOWING IS STRENGTHENED WITH THE VIBROMOTOR ON THE HOPPER.

(02) - WEIGHING CONVEYOR UNDER THE 3 COMPARTMENT AGREGA HOPPER (9 mt)



THIS CONVEYOR ALLOWS THE WEIGHING OF THE AGGREGATE IN THE HOPPER AND AFTER WEIGHING TRANSFERS THE AGGREGATE TO THE TRANSFER BAND. POSITIONED JUST BELOW THE AGREGA HOPPER. MAIN CHASSIS IS MANUFACTURED TO THE NORMS OF ISO 9001 QUALITY AND TO THE DIN NORMS, USING 40 x 80 x 3mm PROFILE AND 3mm. SHEET METAL. ROLL STATIONS ARE PLACED EACH 90 cm TO PREVENT THE FLEE BACK. THE RUBBER BAND IS MADE WITH 8 mm CORD MATERIAL. ROLLS ARE 3''(ø 89 mm). DRIVEN BY REDUCER GROUP. MOTOR POWER IS 2,2 kw.

FACTORY : TRABZON – ERZURUM DEVLET KARAYOLU ÜZERİ 9.Km. AKOLUK BELEDİYE KARŞISI – ÇAĞLAYAN / TRABZON / TURKEY

FACTORY : +90 462 357 30 62 / OFFICE : +90 462 321 07 78 / GSM : +90 549 325 66 70 / WEB : www.bessconcreteblockmachine.com / Email : abdoul@beyazligroup.com



(03) – CONVEYOR BELT (8.5 mt x 0,50 mt x 8 mm) (FIXED)



THIS EQUIPMENT TRANSFERS THE DOSAGED MATERIAL COMING FROM THE AGREGA TRANSFER BAND UNDER THE HOPPER TO THE MIXER.POSITIONED TO END OF THE AGREGA TRANSFER BAND UNDER THE HOPPER.MAIN CHASSIS IS MANUFACTURED TO THE NORMS OF ISO 9001 QUALITY USING 40 x 80 x 3mm PROFILE AND 3mm. SHEET METAL. THERE IS A SCALE THAT PREVENTS ESCAPING BACK OF THE MATERIALS ON THE BAND. THE BAND RUBBER IS MANUFACTURED WITH 4 LAYERS FROM 8 mm. ROLLS ARE 3'(ø 60mm). ROLLS STATIONS ARE PLACED EACH 90 cm. DRIVEN BY MOTOR AND REDUCER GROUP.MOTOR POWER IS 2,2 kw.

(04) - CEMENT SILO 50 TON (BASIC MODEL/DISCHARGE PIPE)

CEMENT STORAGE EQUIPMENT. THE CAPACITY IS 50 TON. BESIDES ARE WALKING STAIRS FOR EMERGENCIES. TO DISCHARGE THE SILO INTO THE CEMENT FEEDING SCREW THERE IS A WAM BRAND VALVE. MANUFACTURED AS STEEL CONSTRUCTION USING 5 mm. SHEET METAL.

FOR EASY SHIPMENT; OPTIONALLY THE SILO CAN BE MANUFACTURED AS DEMOUNTED (BOLTED)

(05) - Ø200 7-9 METER RANGE CEMENT SCREW (WAM)



TAKES THE NEEDED CEMENT FOR MORTAR FROM THE SILO TO FEED THE WEIGHING CONVEYOR. 8'(ø219 mm) MOTOR POWER IS 9,2 Kw. WAM BRAND. SILO CONNECTION POINT IS MOVABLE. POSSIBLE TO TURN ALL ANGLES.



(06) - 50 KG CEMENT SCALE HOPPER (1 BAG)

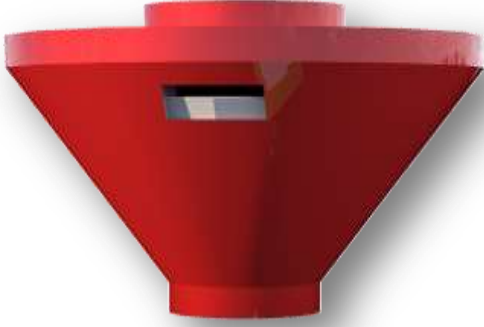

EQUIPMENT TRANSFERS THE REQUIRED CEMENT COMING FROM THE SILO WITH THE CEMENT SCREW TO THE MIXTURE IN THE MIXER. EQUIPMENT HAS 50 KG MEASURING CAPACITY. DISCHARGE PROVIDES BY PNEUMATIC VALVE. POSITIONED ON THE MIXER. LEVEL CONTROL MADE BY OPERATOR. START-STOP OPERATION MADE BY BUTTONS ON THE PANEL. CEMENT MEASURING MADE BY GLASS LEVEL INDICATOR. OPERATOR, PROVIDES DISCHARGE WITH THE PNEUMATIC JOISTIC.

(07) – OPERATOR PLATFORM AND 0,35 m³ PAN MIXER (BOTTOM TRANSMISSION)



MIXER OPERATOR PLATFORM IS WHERE THE OPERATOR CAN OBSERVE THE MORTAR MIXING OPERATION AND CONTROL BY ELECTRIC PANEL ON IT. MORTAR ELECTRIC PANEL IS DESIGNED ACCORDING TO OPERATION ORDER FOR THE MIXTURE. WITH THIS FEATURE IT IS EASY TO USE.

0,35 m³ PAN MIXER; THE MIXER IS PROVIDING HOMOGENEOUS MIXING OF AGGREGATE. MOTOR POWER IS 15 kw. BY THE PALLETS HANDLE - BY BASE WEAR PLATES AND BY ABRASION SHEET METAL HARDOX / ST 52 - A1 QUALITY MATERIAL IS USED. HANDLE SYSTEM IS AS REPLACEABLE DESIGNED. DISCHARGE PROVIDES BY PNEUMATIC VALVE AND JOISTIC.

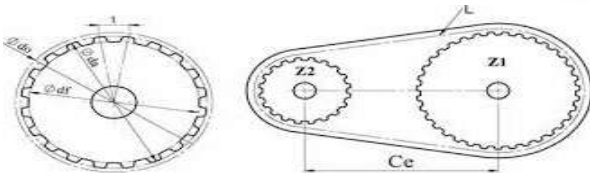

**(08)-CONVEYOR BELT (10 mt x 0.50 mt x 8 mm) (FIXED)**

EQUIPMENT IS POSITIONED ON THE OUTPUT OF THE MIXER. TRANSFERS THE PREPARED MORTAR TO THE MORTAR HOPPER. THE MAIN CHASSIS IS MANUFACTURED TO THE NORMS OF ISO 9001 QUALITY USING 40 x 80 x 3mm PROFILE AND 3mm. SHEET METAL. THERE IS A SHEET METAL THAT PREVENTS ESCAPING BACK OF THE MATERIALS OF THE BAND. THE BAND RUBBERS ARE MANUFACTURED WITH 4 LAYERS FROM 8 mm. CORD MATERIAL. ROLLS ARE 3'(ϕ 60mm). ROLLS POSITIONS ARE PLACED 1 BY EACH 90 cm. DRIVEN BY MOTOR AND REDUCER GROUP.MOTOR POWER IS 2,2 kw.

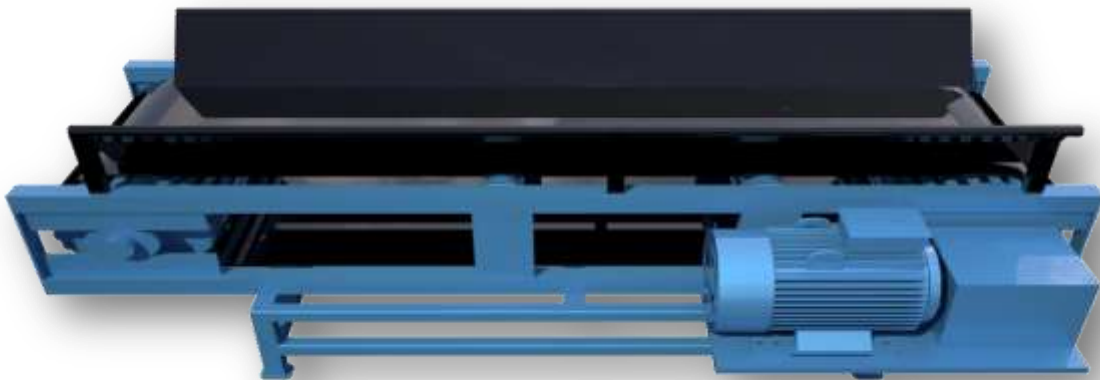
(09) – MINI CONVEYOR BELT BETWEEN MACHINE HOPPERS (LEFT-RIGHT MOVABLE)

EQUIPMENT TRANSFERS THE THICK MORTAR COMING FROM THE MIXER TO THE THICK MORTAR HOPPER, THIN MORTAR TO THE THIN MORTAR HOPPER. DESIGNED TO MOVE LEFT-RIGHT. MOTOR POWER IS 2,2 KW. MOVES WITH BUTTON ON THE ELECTRIC PANEL IN FRONT OF THE MIXER OPERATOR.





(10) – PRS 602 AUTOMATIC DOUBLE MORTAR HOPPER MACHINE



VIBRATION SYSTEM/ STRIKE FORCE ADJUSTABLE/VIBRATION FORCE : 36.500 KG

MAIN CHASSIS / CAN BE OPENED FROM TWO SIDES

AUTOMATIC AUTOMATION SYSTEM / PLC-SCHNEIDER – SIEMENS

EASY HEIGHT ADJUSTMENT VIA JACK –GRILL SHAKE SYSTEM

NUMBER OF MORTAR HOPPER :2 PIECE // MORTAR SILO CAPACITY : 0,60 m³ // PRODUCTION TYPE : SINGLE ROW PRESS

MACHINE TOTAL WEIGHT : 9.000 KG // TOTAL MOTOR POWER : 28 KW

MAIN CHASSIS : 150 x 150 x 6 mm.CLOSED PROFILE // WIDTH :220 cm.// LENGTH:1150 cm.// HEIGHT :250 cm

COLUMN SHAFTS : 80 mm.DIAMETER 4 PIECES CHROME SHAFT BEARINGS

HYDRAULIC PISTONS: BRONZ BEARING AND SPECIAL CUSHIONING SYSTEM IS USED



FACTORY : TRABZON – ERZURUM DEVLET KARAYOLU ÜZERİ 9.Km. AKOLUK BELEDİYE KARŞISI – ÇAĞLAYAN / TRABZON / TURKEY

FACTORY : +90 462 357 30 62 / OFFICE : +90 462 321 07 78 / GSM : +90 549 325 66 70 / WEB : www.bessconcreteblockmachine.com / Email : abdoul@beyazligroup.com



Please consider the environment before printing this document

BEYAZLI GRUP LTD. ŞTİ

BESS



MORTAR CAR BOTTOM PLATE SHEETS: ST 52 A1

MORTAR UNITS:ST 52 A-1 QUALITY// MORTAR UNIT STABILIZER ROLLER BEARINGS: SKF OR FAG

ALL THE WHEELS ON THE MACHINE: HIGH CARBON CONTENT CK-45 OR 4140

SURFACE HARDENING VIA INDUCTION



FACTORY : TRABZON – ERZURUM DEVLET KARAYOLU ÜZERİ 9.Km. AKOLUK BELEDİYE KARŞISI – ÇAĞLAYAN / TRABZON / TURKEY

FACTORY : +90 462 357 30 62 / OFFICE : +90 462 321 07 78 / GSM : +90 549 325 66 70 / WEB : www.bessconcreteblockmachine.com / Email : abdoul@beyazligroup.com



Please consider the environment before printing this document



LOWER VIBRATOR QUANTITY : 2 x 5,5 kw. SPECIAL MOTOR.// **UPPER VIBRATOR QUANTITY:** 2 x 0,75 kw VIBROMOTOR-OPTIONAL // **VIBRATION COOLING CAPACITY :** 22.000 Kcal. // **ALL VIBRATIONS:** IT GIVES A MINIMUM VIBRATION TO THE MACHINE BODY USING A SPECIAL DAMPENING SYSTEM.



HYDRAULIC BLOCK UNITS: PRODUCED WITH ACCURACY ON THE FULL AUTOMATIC CNC LATHES USING SFERO MATERIALS. FOR THE CLEANING OF THE UNIT AND SURFACE COATING ARE DIFFERENT TYPES CHEMICAL MATERIALS USED.

HYDRAULIC COOLING UNIT : FAN SYSTEM/OPTIONAL

HYDRAULIC PUMP: POURING TYPE HEMA

HYDRAULIC WORKING PRESSURE: 150 BAR

HYDRAULIC UNIT ENGINE POWER : 15,5 Kw

HYDRAULIC OIL TANK CAPACITY: 700 LT

HYDRAULIC UNIT MOTORS : USED VOLT-GAMAK BRAND WITH THE ACCORDANCE OF ISO QUALITY STANDARDS.

PRESSING SPEED: 28 Sec. // **PALLET DIMENSION:** 85cm x 95cm x 4cm

PRODUCTION CAPABILITY : INTERLOCKING CONCRETE PAVER (**ONE PRESS**) : 16 Pcs.// (**8 HOURS**) 400 m²

PRODUCTION CAPABILITY : 15 x 40 x 20cm BRICKS (**ONE PRESS**) : 8 Pcs. // (**8 HOURS**) 8.000 Pcs.

PRODUCTION CAPABILITY : 20 x 40 x 20cm BRICKS (**ONE PRESS**) : 6 Pcs. // (**8 HOURS**) 6.000 Pcs.

PRODUCTION CAPABILITY: 25 x 40 x 20cm BRICKS (**ONE PRESS**) : 4 Pcs. // (**8 HOURS**) 4.000 Pcs.

FACTORY : TRABZON – ERZURUM DEVLET KARAYOLU ÜZERİ 9.Km. AKOLUK BELEDİYE KARŞISI – ÇAĞLAYAN / TRABZON / TURKEY

FACTORY : +90 462 357 30 62 / OFFICE : +90 462 321 07 78 / GSM : +90 549 325 66 70 / WEB : www.bessconcreteblockmachine.com / Email : abdoul@beyazligroup.com





OTHER

ALL MECHANICAL PARTS ARE MODULAR AND STANDARD PRODUCTION. THERE IS SPARE PARTS INVENTORY. PROVIDING YOU GREATLY SAVE YOUR TIME BECAUSE OF THE OPENING CHASSIS BY CHANGING THE MOULD. GIVES YOU THE POSSIBILITY TO PRODUCE ALSO INSULATED BLOCKS USING THE OPTIONALLY EQUIPMENTS.

PRODUCTION STAFF: 6 EMPLOYES (1 FOR MACHINE // 1 FOR MIXER // 1 FOR FORKLIFT // 1 FOR LOADER // 2 FOR PACKAGING) DURING THE COMMISSIONING STAGE OF THE MACHINE WE PROVIDE TRAINING TO THE STAFF DETERMINED BY YOU, FREE OF CHARGE.

EXPORT TRANSPORT VOLUME AVERAGE : EXCEPT THE PALLETS 1 Pcs. 40 OT + 3 Pcs. 40 HQ CONTAINER.



(11) – FRONT OUTPUT CHAIN CONVEYOR

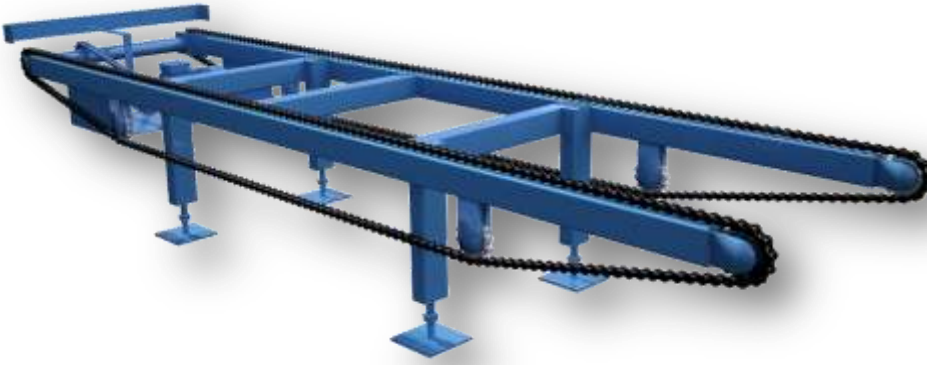

IT IS THE LIFTING SYSTEM FOR THE PRODUCTS PRESSED BY THE MACHINE ON THE PALLETS TO THE FRONT FULL STACKING ROBOT. WORKS WITH THE HELP OF MOTOR WITH REDUCTOR AND CHAIN GEAR. START-STOP ITSELF ACCORDING TO COMMAND FROM THE SWITCH ON IT. ENGINE POWER IS 2.2 KW.



(12)- FRONT FULL PALLET STACKING ROBOT

IT IS THE LIFTING SYSTEM FOR THE PRODUCTS PRESSED BY THE MACHINE ON THE PALLETS. STACKS THE FULL PALLETS COMING FROM THE FRONT OUTPUT CONVEYOR THROUGH THE SENSORS ON IT. MOVES UP-DOWN THROUGH HYDRAULIC VALVE AND PISTON.

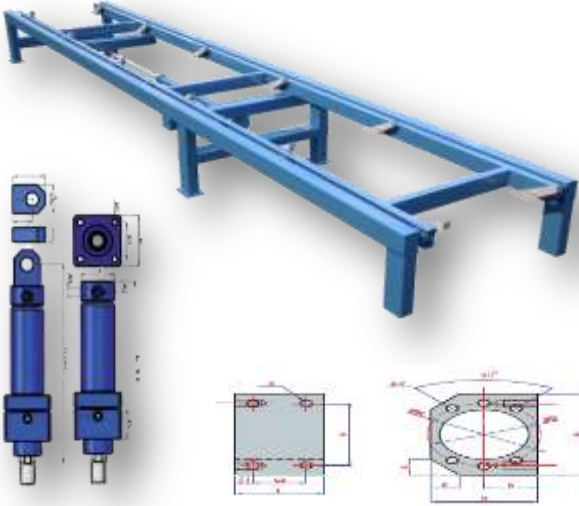

**(13)- REAR ENTRY CLAWED CONVEYOR**

CARRY THE PALLETS COMING FROM EMPTY PALLET ROBOT TO THE MANUAL COLLECTING ROBOT AND THE MACHINE. THROUGH THE CLAW, PRODUCTS ON THE PALLET CARRIED EASILY BY MANUAL ROBOT. FORWARD-BACK ORDER COMES FROM SWITCH. BOX PROFIL USED ON THE MAIN CHASE. CLAWS MANUFACTURED BY SPECIAL SHEET MATERIAL.

(14)- REAR EMPTY PALLET ROBOT (UNLOADER)

IS THE LIFTING SYSTEM FOR THE PALLETS TAKEN BY THE FORKLIFT FROM THE DRYING ROOM SEPERATING ONE BY ONE. THROUGH THE SENSORS ON IT SEPERATES THE PALLETS BY THE HYDRAULIC VALVE AND PISTON.

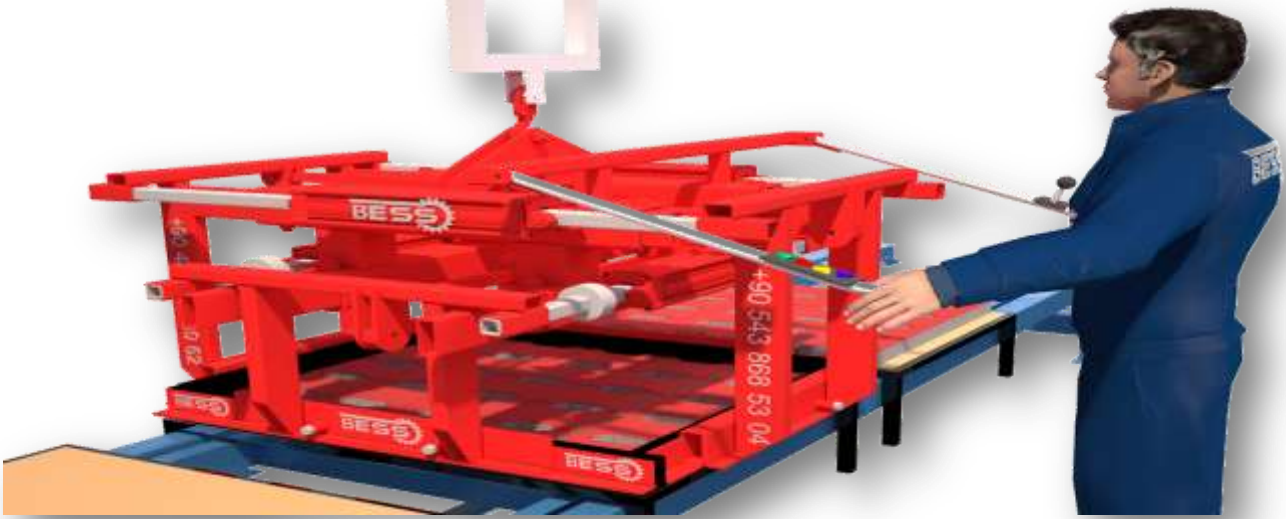

**(15) – MANUAL COLLECTING ROBOT**

CURED AND DRIED PRODUCTS COMING FROM REAR UNLOADER ROBOT, TAKEN FROM THE PALLETS WITH OPERATOR CONTROL AND STACKED ON EURO SHIPPING PALLETS. MOVES WITH PNEUMATIC SYSTEM. PROVIDES ITS COLLECTING OPERATION QUICKLY AT ONE POINT. WITH MOTOR ON IT, MOVES RIGHT-LEFT AND UP-DOWN. MOTOR POWER IS 0,2 KW.

(16) – AUTOMATIC MACHINE ELECTRIC UNIT (PLC) 6 / 16

OPERATING SYSTEM EXIST OF COLLECTED POWER AND CONTROL PANELS GATHERED IN ONE UNIT . ALL MOVEMENTS OF THE MACHINE ARE PERFORMED BY THE PLC UNIT. MOVEMENTS ARE PROVIDED VIA CONTROL HANDLE AND IS EASY TO USE. ALL PANELS ARE INCLUDED IN HIGH PROTECTION CLASS. USED MATERIALS ARE **SCHNEIDER AND SIEMENS** BRAND. OPTIOANALLY REMOTE CONTROL VIA WIFI IS AVAILABLE. UNIT IS PROGRAMMED WITH REMOTE CONTROL FOR MAINTANENCE AND FAULT DETECTION.THERE ARE STOP BUTTONS TO INTERVENE IN CASE OF EMERGENCY.



(17) – 6 SERIAL / STEEL FRAMED PALLET WITH PROFILE

CONCRETE BLOCKS ARE PRESSED ON THIS EQUIPMENT. DIMENSIONS **85cm x 95cm x 4cm**. PRODUCTS GOES FROM EMPTY PALLET ROBOT (UNLOADER) TO MANUAL COLLECTING ROBOT WITH REAR ENTRY CONVEYOR AFTER THE DRYING PROCESS. PRODUCTS COLLECTS HERE, GOES TO MACHINE AND STARTS PRESSING. MANUFACTURED WITH



HIGH QUALITY TREES WHICH IS SMOOTH AND DRY, ATTACHED TO ONE ANOTHER WITH SEA GLUE, BOTTOM AND TOP SURFACES OF THE WOOD IS CLEANED WITH PLANING PROCESS AND HUMADITY IS %20. EDGE SHEET METAL ST 52 / A1, WIDTH IS 4 cm AND THICKNESS IS 4 mm.

(18) – DIFFERENT TYPES PAVING BLOCK MOULDS (ST 52)



PAVING BLOCK MOULD MONOBLOCK : MANUFACTURED FROM SPECIAL MOULD STEEL. PRESSING LININGS ARE TO BE ACCUSTOMED IN TO THE MOULD SECTION. IS READY TO USE AFTER HARDENING WITH INDUCTION.
STEEL CONSTRUCTION MOULDS : AFTER DESIGNING THE MOULDS DIMENSIONS WILL BE BROUGHT TO THE DESIRED VALUE USING WEAR RESISTANT SPECIAL SHEET METAL WITH STEEL CONSTRUCTION SYSTEM. CURBSTONE MOULD BLADES ARE READY TO USE AFTER SAWDUST REMOVAL PROCESSING FROM THE CK 45 SHEET METALS AND HARDENINGS PROCESS VIA INDUCTION.

FACTORY : TRABZON – ERZURUM DEVLET KARAYOLU ÜZERİ 9.Km. AKOLUK BELEDİYE KARŞISI – ÇAĞLAYAN / TRABZON / TURKEY

FACTORY : +90 462 357 30 62 / OFFICE : +90 462 321 07 78 / GSM : +90 549 325 66 70 / WEB : www.bessconcreteblockmachine.com / Email : abdoul@beyazligroup.com





SAMPLE CONCRETE HOLLOW BLOCK MODELS



SAMPLE CONCRETE BLOCK MODELS

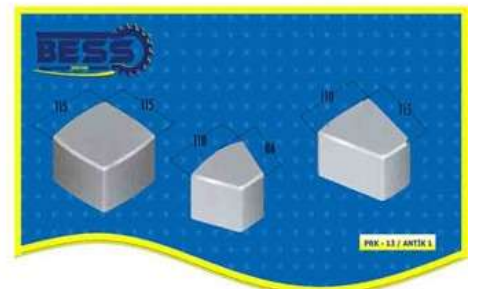
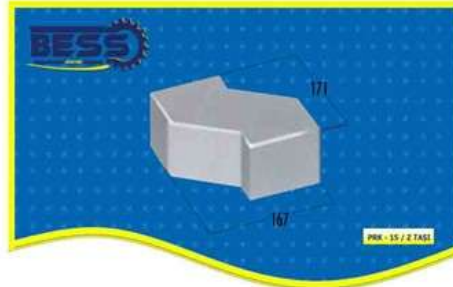

COMMERCIAL TERMS

CODE : B-012 THIS CAMPAIGN IS VALID UNTIL 30.06.2019 DELIVERY TIME ; MAXIMUM 90 WORKING DAYS. OPERATOR TRAINING ; TRAINING AND OPERATOR SERTIFICATE WILL BE PROVIDED FREE OF CHARGE.

INFRASTRUCTURE PROJECT ; WILL BE PROVIDED THROUGH OUR COMPANY FREE OF CHARGE AFTER DISCOVERING AND SOME NECESSARY STUDIES ARE MADE.

COMMISSIONING AND TEST PRODUCTION ; THE EXPENSES FOR VISA (IF NECESARRY) FOR THE TECHNICAL TEAM - FLIGHT TICKETS - TRANSFER - ACCOMODATION AND HYDRAULIC OIL FOR THE MACHINE WILL BE PAID BY THE PURCHASER.

SHIPPING ; CAMPAIGN PRICES ARE FACTORY DELIVERY (EX-WORKS). SHIPPING AND ALL INSURANCE COSTS ARE FOR THE PURCHASER, LOADING COSTS ARE FOR THE SELLER. OUR COMPANY PROVIDES ALL LOGISTICAL SUPPORT FOR THE SHIPMENT OF THE CUSTOMERS. **TAXES ;** BY DOMESTIC SALES 18% , INCENTIVE AND LEASING 1% APPLIED. BY OVERSEA SALES TAXES ARE NOT REQUIRED.

METHOD OF PAYMENT ; 30% DOWNPAYMENT BY ORDERING AFTER SIGNING OF THE OFFICIAL CONTRACT, INTERIM PAYMENT OF 30% AND REMAINDER 40% BY DELIVERY VIA BANK TRANSFER. ALL OF OUR PRODUCTS ARE SUITABLE FOR SALE VIA L/C - BANK LOAN AND LEASING.

OUR AGREEMENTS ; ARE APPROVED BY CHAMBER OF INDUSTRY AND TRADE FOR DOMESTIC SALES, BY OVERSEAS SALES APPROVED BY THE EXPORTERS UNION. IT HAS THE INTERNATIONAL NORMS AND VALIDITY.

WARRANTY ; ALL OF OUR PRODUCTS ARE UNDER WARRANTY AGAINST MANUFACTURING FAILURES FOR A PERIOD OF 2 YEARS. OPTIONALLY WARRANTY PERIOD CAN BE EXTENDED UPTO 2 + 3 = 5 YEARS BY ADDING THE PRICE DIFFERENCE OF 5%













AFTER SALES AND SPARE PARTS ;BY POSSIBLE FAILURES THE INTERVENE TIME IS DOMESTIC 48 HOURS - INTERVENE TIME GLOBALLY IS MAXIMUM BETWEEN 72 AND 120 HOURS. THIS TIME SCHEDULE IS NOT RELEVANT FOR COUNTRIES WHICH ARE REQUESTING A INVITATION FOR VISA. OUR WARRANTY COMMITMENTS ARE SIGNED BY THE OFFICIAL FORMAL CONTRACT.



PHOTO GALLERY



**CONTACT**

TURKEY  Contact Person: Gökhan Özdemir Cell : +90 (549) 325 66 67 Phone : +90 (543) 868 53 04 E-mail: gokhan@beyazligroup.com	RUSSIA  Contact Person: Tolga Kalelioğlu Cell : +90 (549) 325 66 62 Phone : +90 (462) 321 07 78 E-mail: tolga@beyazligroup.com	FRANCE  Contact Person: Mohamed Thiam Cell : +90 (549) 325 66 60 Phone : +90 (462) 321 07 78 E-mail: mohamed@beyazligroup.com
LIBYA  Contact Person: Mouad Mazour Cell : +218 (911) 620 035 Phone : +90 (541) 868 54 59 E-mail: mouad@beyazligroup.com	GEORGIA  Contact Person: Lasha Gabaidze Cell : +995 (571) 912 626 Phone : +90 (549) 325 66 64 E-mail: lasha@beyazligroup.com	SAUDI ARABIA  Contact Person: Abdurrahim Temur Cell : +90 (544) 549 41 99 Phone : +90 (462) 321 07 78 E-mail: temur@beyazligroup.com
AZERBAIJAN  Contact Person: Anar Nazarov Cell : +994 (702) 002 677 Phone : +90 (549) 325 66 61 E-mail: gokhan@beyazligroup.com	UKRAINE  Contact Person: Tolga Kalelioğlu Cell : +90 (549) 325 66 62 Phone : +90 (462) 321 07 78 E-mail: tolga@beyazligroup.com	OMAN  Contact Person: Abdurrahim Temur Cell : +90 (544) 549 41 99 Phone : +90 (462) 321 07 78 E-mail: temur@beyazligroup.com
ALGERIA  Contact Person: Mouad Mazour Cell : +90 (541) 868 54 59 Phone : +90 (462) 321 07 78 E-mail: mouad@beyazligroup.com	AFRICA  Contact Person: Abdoul Wahabou Cell : +90 (549) 325 66 70 Phone : +90 (462) 321 07 78 E-mail: abdoul@beyazligroup.com	MOROCCO  Contact Person: Soumia Boukebir Cell : +90 (549) 325 66 69 Phone : +90 (462) 321 07 78 E-mail: soumia@beyazligroup.com



www.beyazligroup.com /// www.bessconcreteblockmachine.com /// abdoul@beyazligroup.com

FACTORY : TRABZON – ERZURUM DEVLET KARAYOLU ÜZERİ 9.Km. AKOLUK BELEDİYE KARŞISI – ÇAĞLAYAN / TRABZON / TURKEY

FACTORY : +90 462 357 30 62 / OFFICE : +90 462 321 07 78 / GSM : +90 549 325 66 70 / WEB : www.bessconcreteblockmachine.com / Email : abdoul@beyazligroup.com



Please consider the environment before printing this document